



"Pitch & Roll" S&R Detector Test System for Seats

- ✦ **Bucket, split and bench seats; individual or full row**
- ✦ **"Roll", vertical and lateral response, simultaneously**
- ✦ **"Pitch", vertical and fore-aft response, simultaneously**
- ✦ **Switch-selectable: Pitch or Roll**
- ✦ **Better simulates road vibration inputs than "vertical-only" excitation**
- ✦ **Quiet: "@ Rest, Ready" 30 dBA, \approx 1 sone N(10) loudness, depending on Quiet Room**
- ✦ **Quiet: "Running, without seat" <40 dBA typical, depending on S&R PSD profile & Quiet Room**
- ✦ **Reproduces road-measured acceleration time histories plus sine and random PSD vibration**
- ✦ **Realistically stimulates S&Rs found on roads, test tracks and road simulators**
- ✦ **Use for S&R, aging & durability**



Buzzes, squeaks and rattles (S&Rs) in vehicles are a major source of customer dissatisfaction, complaints in J.D. Power surveys, and warranty claims and costs. MB Dynamics delivers affordable turnkey systems to help OEMs & their suppliers develop and produce vehicles free of squeaks & rattles, with measurable quality.

Key Benefits

- ❖ Demonstrate quality to OEMs & deliver S&R-free seats
- ❖ Use for product validation, during product launch and for in-plant Quality Audits
- ❖ Test rig operating noise does not mask S&Rs
- ❖ Electrodynamic (permanent magnet) excitation – no hydraulics nor eccentric mass devices
- ❖ Much less expensive & quieter than hydraulic MAS table that requires highly trained operators
- ❖ Shorten, and reduce risk to, launch schedules
- ❖ Identify assembly flaws to eliminate S&Rs at source
- ❖ Identify supplier S&R issues and feedback findings up supplier chain
- ❖ Troubleshoot and correct pre-production and production S&R issues
- ❖ Quiet enough to use acoustic data acquisition and analysis to measure and quantify S&R-free
- ❖ Existing quality people operate; little maintenance
- ❖ MEQ supplier to Johnson Controls



Vertical and Roll – The 2 Most Important Directions, Combined!

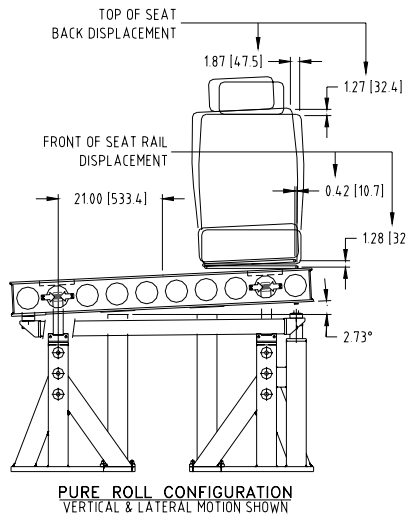
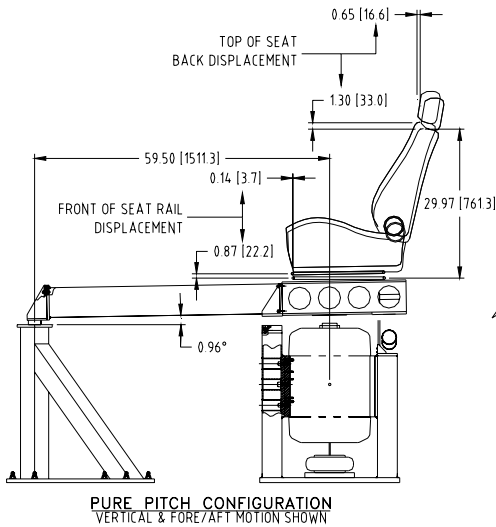

This test rig achieves simultaneous vertical, lateral and roll response when excited vertically in the "Roll" configuration. Simultaneous vertical, fore-aft and pitch response is achieved when exciting vertically in the "Pitch" mode. Such motions can stimulate more S&Rs than pure vertical input, adding to the value of the test rig for detecting root causes of S&Rs.

Study this drawing to see this coupled motion. The Mounting Table is supported in front by the V-LINK pivot arm and driven by two MB patented Energizer BLACKs in parallel. In the "Pitch" plot, the BLACKs excite in-phase into a typical seat. Normalizing motions to 1 unit of vertical input at

the BLACK centerline, the fore-aft motion at the seat rail is 0.14 units and 0.65 units fore-aft at the top of the seat back. In the "Roll" plot, BLACKs excite out-of-phase. 1 unit of vertical input at the BLACK centerline yields 1.27 units vertically & 1.87 laterally at the top of the seat back (right shoulder) due to 2.7 deg of roll. Roll excitation of S&Rs is important in SUVs, trucks and vehicles with a high center of gravity that makes them susceptible to vehicle roll.

Weight-Optimized Fixture and Seat Bracket Design

Because S&R accelerations are often $\leq 5 \text{ m/s}^2$ RMS and frequencies are normally ≤ 100 Hz, rigid and massive fixtures are unnecessary. Oversized, heavy fixtures unnecessarily increase shaker force capacities at the expense of quiet operation. An egg-crate, interlocking plate design for MB's magnesium mounting table with plentiful lightening holes, high-strength aluminum seat holding brackets, and minimal plate surface area normal to the vibration direction (minimizing the "speaker effect" of these radiating surfaces) all contribute to a structurally-stiff, light-weight, low-noise-radiating design.

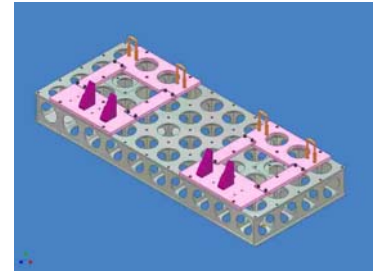

System Configurations

MB's Energizer BLACKs need no cooling during S&R tests because their permanent magnets (no field coils) generate minimal heat. The "Pitch & Roll" S&R Detector can however be used for aging and durability work, and is then forced-air cooled. For applications requiring quiet operation *and* higher durability accelerations, MB offers its patented lever arm mechanism that doubles forces generated by a BLACK. An ergonomic advantage is that the mounting surface for the seat is approximately 45cm above the floor not 100cm, thus aiding load/unload.

The following table lists excitation performance capabilities of several system configurations. With cooling, g's of acceleration shown in the Table can be doubled. G's can be doubled again with the use of lever arms.

System Configurations for S&R, Uncooled

(with 60kg Mounting Table and two 5kg BLACK moving elements)

Configuration	Seat, kg	MB Fixture, kg	Total Payload, kg	Performance, g's		
				Sine, pk	Random, RMS	Shock, pk
Single front seat	45	18	63	1.5	0.9	1.8
Front or rear row	70	35	105	1.2	0.7	1.4
Bench	75	18	93	1.3	0.8	1.6

Standard Deliverables

- ❖ 1500mm X 635mm magnesium mounting table & pivot arm assembly
- ❖ Two Energizer BLACK vibration exciters and power supplies
- ❖ S&R Control Console with SINE, RANDOM & Time History software
- ❖ PC control via remote keyboard & mouse, display, and printer
- ❖ Seat holding fixtures for one seat
- ❖ 19" instrument rack, accelerometers and cables
- ❖ Installation, start-up, and training
- ❖ One-year, return-to-factory warranty
- ❖ User documentation and drawings

Options

- ❖ Seat holding fixtures for other seats
- ❖ Quiet cooling packages for BLACKs
- ❖ Lever arm assemblies for 2X force
- ❖ Acoustic data acquisition instruments
- ❖ S&R Metrics, dBA vs. frequency, etc.
- ❖ S&R Metrics, Loudness vs. time, etc.
- ❖ Quiet Room
- ❖ S&R Test Executive software
- ❖ Acquire drive-files / seat accelerations