

Airbag control units (ECUs) in advanced airbag systems process multiple sensor inputs to determine the type and severity of a crash plus occupants' restraint, size, weight, and position. The ECU decides which multiple airbags to deploy and with how much force.

Front impact sensors (FIS) supply signals at a very early stage to define frontal impact forces. Side impact sensors (SIS) recognize a lateral impact and characterize collision forces to enable the ECU to rapidly trigger side airbags.

Proving that ECU software and algorithms reliably discriminate **MUST FIRE** from **NO FIRE** conditions for a variety of crash scenarios is of paramount importance – to consumers, OEMs, suppliers, governments, insurance companies, and advocacy groups.

Jobs-to-be-done to “prove” ECU & sensor system performance

- ❖ Shock test ECU in lab with actual crash time histories
 - Frontal (fore-aft or longitudinal direction)
 - Side (lateral direction)
- ❖ Simultaneously shock test ECU with FIS and SIS to inject their acceleration signals to ECU to validate its triggering
- ❖ Synchronize ECU, FIS and SIS actual crash events within 1 msec of one another to simulate real-world behavior
- ❖ Perform “what if” lab tests on other crash scenarios to validate sensor system performance over the range of crash events for each vehicle platform
- ❖ Acquire sensor parameters and report ECU **MUST FIRE** (MF) and **NO FIRE** (NF) conditions, such as
 - Time To Fire (TTF)
 - Time of Closure (TOC)
 - Acceleration and velocity at TTF
 - Customer-specific parameters

MB Deliverables to “prove” performance and reliability

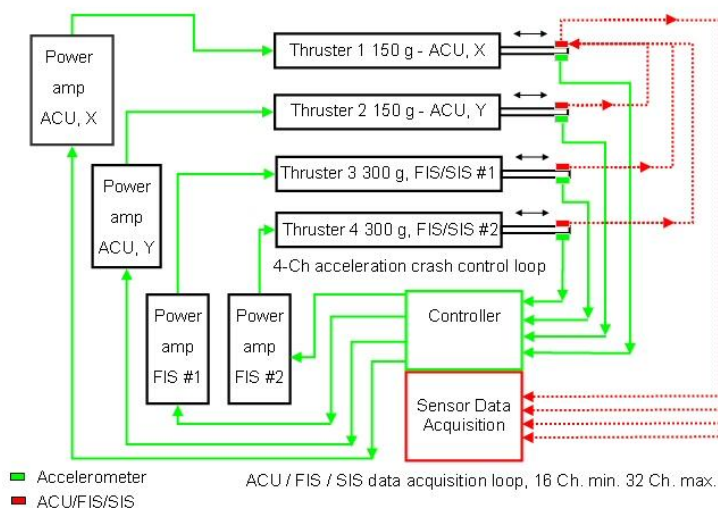

MB Deliverables to “prove” sensor system performance & reliability

Specification	150g Thruster & Amplifier	300g Thruster & Amplifier
Shock direction	Horizontal only	Horizontal only
Shock events	Actual crash events, haversine & half sines	Actual crash events, haversine & half sines
Shock event duration	< 100 msec for actual crash	< 100 msec for actual crash
Max. shock acceleration	150 g’s peak with 1.0kg payload	300 g’s peak with 1.0kg payload
Max. displacement	600mm between stops	300mm between stops
Max. velocity change, actual crashes	65 kph	65 kph
Frequency response	> 800 Hz (2X sensor’s 400 Hz), enhances controllability, repeatability & small error	> 800 Hz (2X sensor’s 400 Hz), enhances controllability, repeatability & small error
Max. payload	1.0 kg, excluding fixture	1.0 kg, excluding fixture
Armature weight	15kg, including MB-supplied fixture	13kg, including MB-supplied fixture
Armature suspension	Air bearings	Air bearings
Thruster cooling	Air-cooled with fan assembly, < 50 dBA	Air-cooled with fan assembly, < 50 dBA
Thruster reaction base; no seismic mass required	Minimizes reaction forces input to facility	Minimizes reaction forces input to facility
Basic amplifier architecture	Class D	Class D
Input power	200 Amps per phase, nominal 480 VAC, 3 phase, 50/60 Hz	200 Amps per phase, nominal 480 VAC, 3 phase, 50/60 Hz
Amplifier cooling	Air-cooled with integral fans, 60 dBA	Air-cooled with integral fans, 60 dBA
Interlocks and safety circuits	E-STOP; control panel; LEDs for conditions	E-STOP; control panel; LEDs for conditions
Thruster and base dimensions	2.8m X 0.9m X 0.4m High	2.0m X 0.9m X 0.4m High
Amplifier dimensions	1.0m X 0.8m X 0.8m	1.0m X 0.8m X 0.8m
ECU / FIS / SIS fixture dimensions	125mm X 125mm	125mm X 125mm

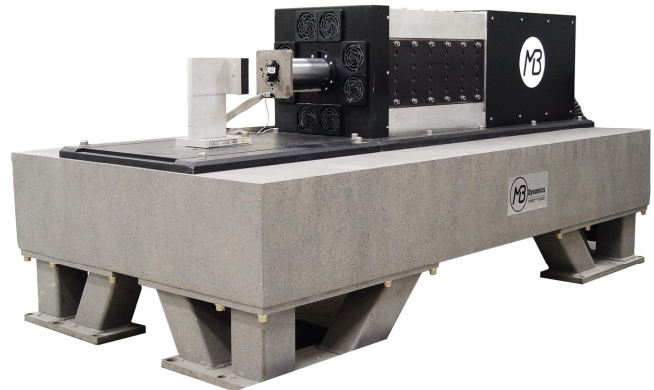

Thruster Controller and Sensor Measurement System Features:

Using the Thruster Controller an operator imports ASCII actual measured crash time histories, selects the “meaningful” portion of the crash event, filters it and applies compensation. The controller then faithfully reproduces the edited waveform in order to measure ECU parameters, including TTF & TOC from an ECU, FIS, & SIS. Other controller functions include:

- ❖ Manipulate actual crash acceleration time histories
- ❖ Edit crashes to fit within thruster/amplifier acceleration, velocity, displacement, current, voltage & frequency limits; recommends ways to edit events not within limits
- ❖ Resample actual crashes, high-pass/low-pass filter, and truncate/scale peaks
- ❖ Control and position thruster armature, tailored to each crash event
- ❖ Minimize pre-event motion that confuses ECU algorithms creating MF from NF events
- ❖ Minimize abrupt acceleration launches at beginning of crash
- ❖ Adjust DAC signal to differing system transfer functions
- ❖ Control errors to <5% of peak g’s at each Δt
- ❖ Simultaneously start multiple thrusters within 1 msec of one another (overlay of 4)

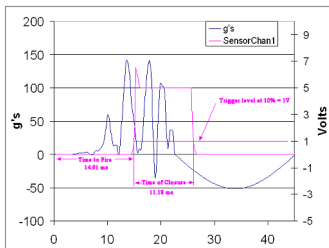
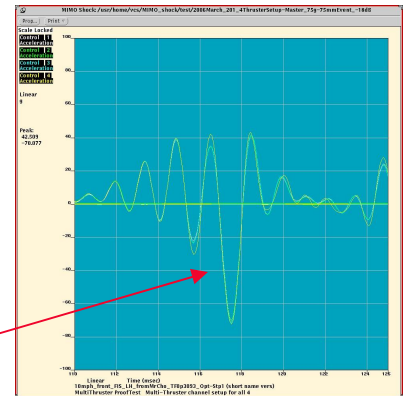

The Sensor Measurement System samples each of 16 or 32 sensor channels at 52 kHz to:

- ❖ Determine the T_0 value for the control acceleration measured, taking account of process delays between DAC and each thruster’s response
- ❖ Measure the sensor channel trigger points
- ❖ Calculate the sensor channel TTF and TOC from the T_0 value above
- ❖ Produce reports of BOTH tabular and graphic results for every sensor channel employed in the measurement system